

# Wiring Diagrams

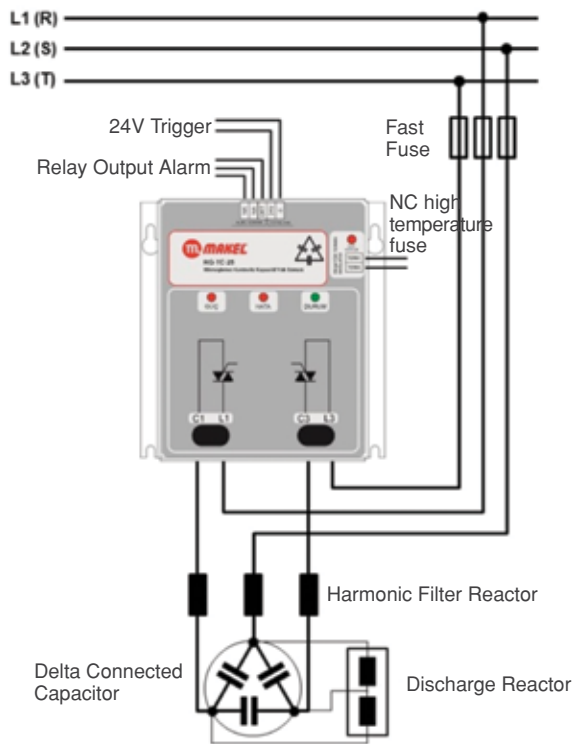

Recommended electrical connection diagram of RG-TC-12 and RG-TC-25 modules with harmonic filter reactor and discharge reactor. The structure of RG-TC-12 and RG-TC-25 modules, terminals and connection diagrams are equivalent.

# Wiring Diagrams

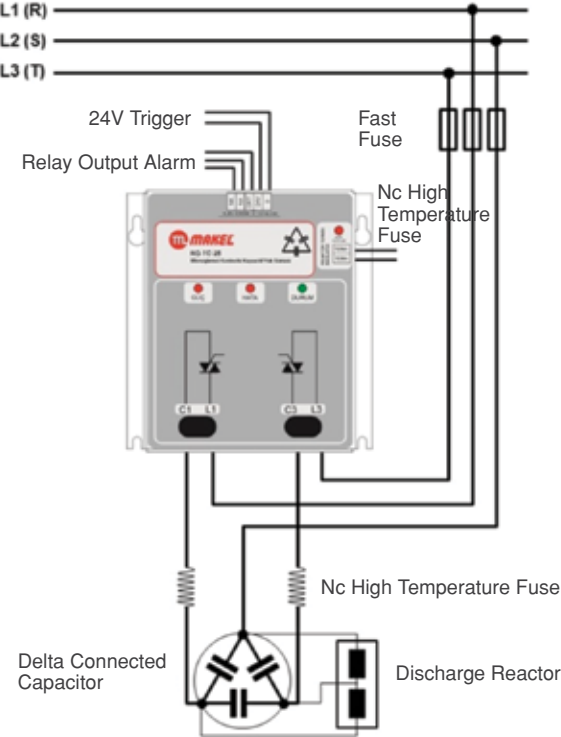

Recommended electrical connection diagram of RG-TC-12 and RG-TC-25 modules with harmonic filter reactor and discharge reactor. The structure of RG-TC-12 and RG-TC-25 modules, terminals and connection diagrams are equivalent.

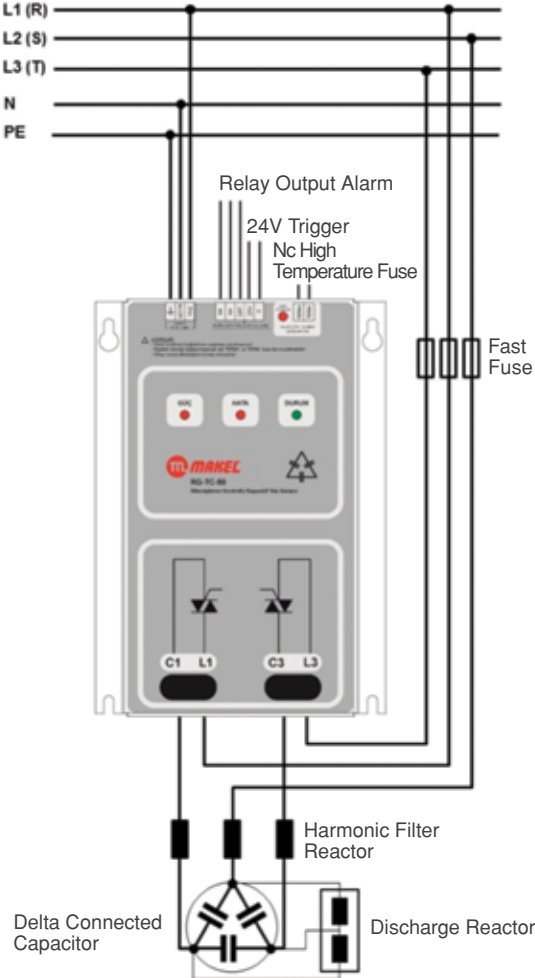

Recommended electrical connection diagram of RG-TC-50 and RG-TC-80 modules with harmonic filter reactor and discharge reactor. The structure of the RG-TC-50 and RG-TC-80 modules, terminals and connection diagrams are equivalent.

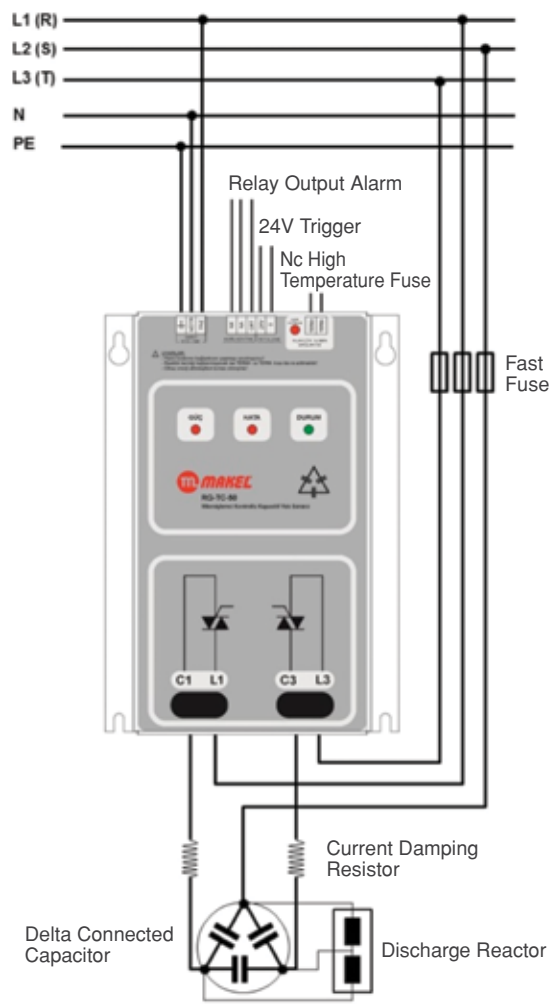

Recommended electrical connection diagram of RG-TC-50 and RG-TC-80 modules with harmonic filter reactor and discharge reactor. The structure of the RG-TC-50 and RG-TC-80 modules, terminals and connection diagrams are equivalent.

# Wiring Diagrams

RG-TR-05-Diagram

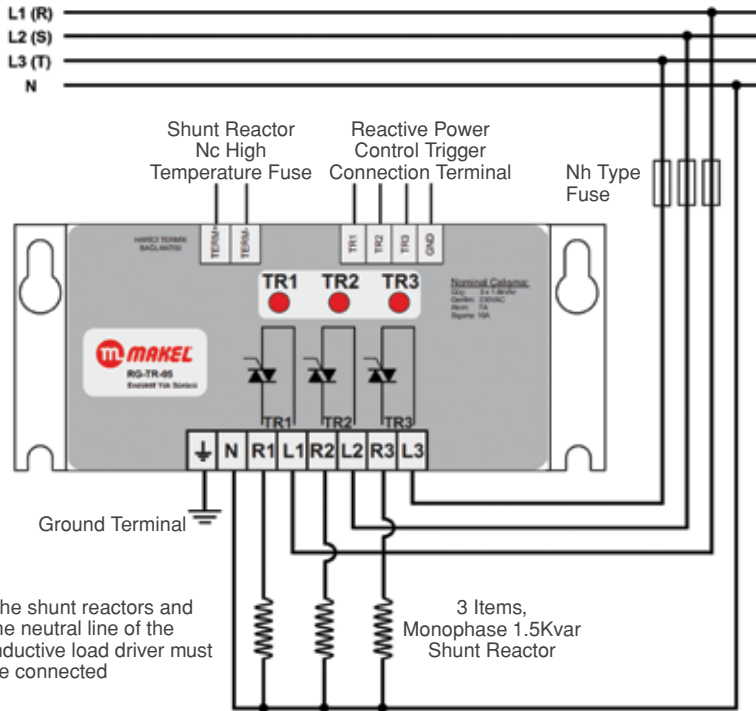

The shunt reactors and the neutral line of the inductive load driver must be connected

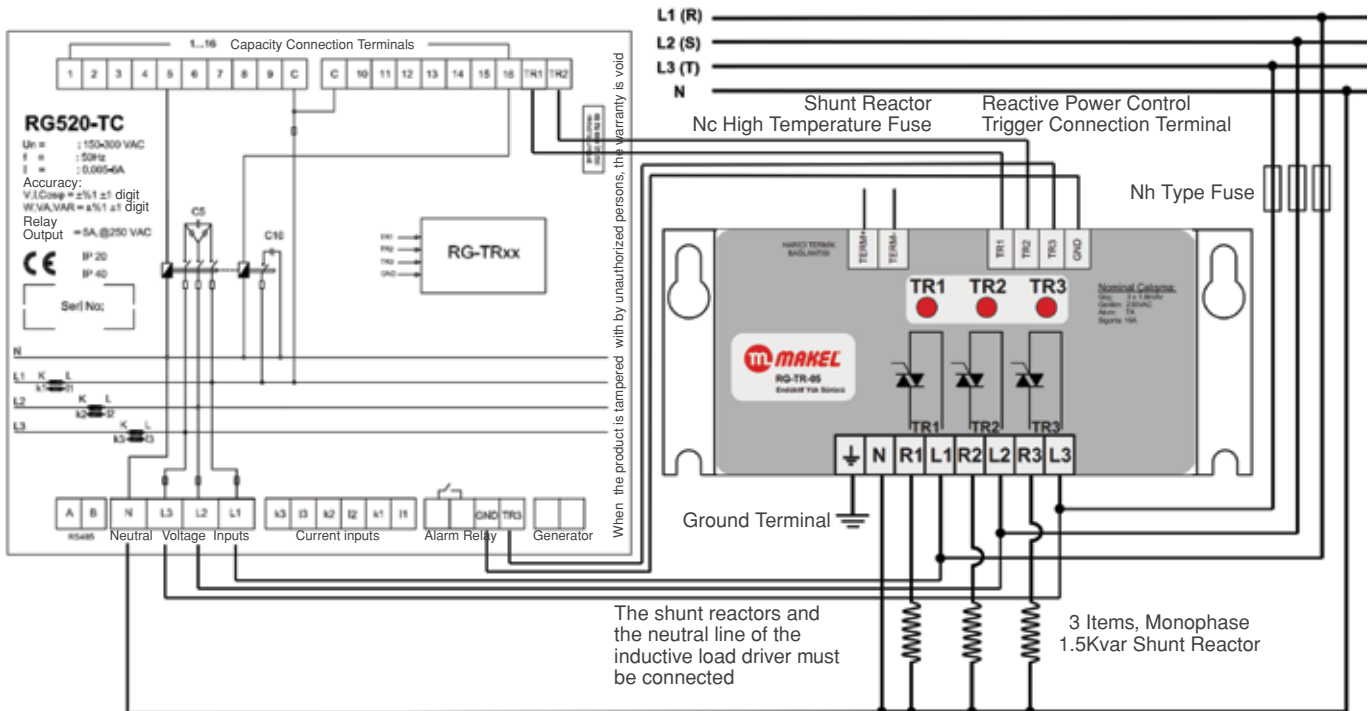

The shunt reactors and the neutral line of the inductive load driver must be connected

# RG-TR-20-Diagram

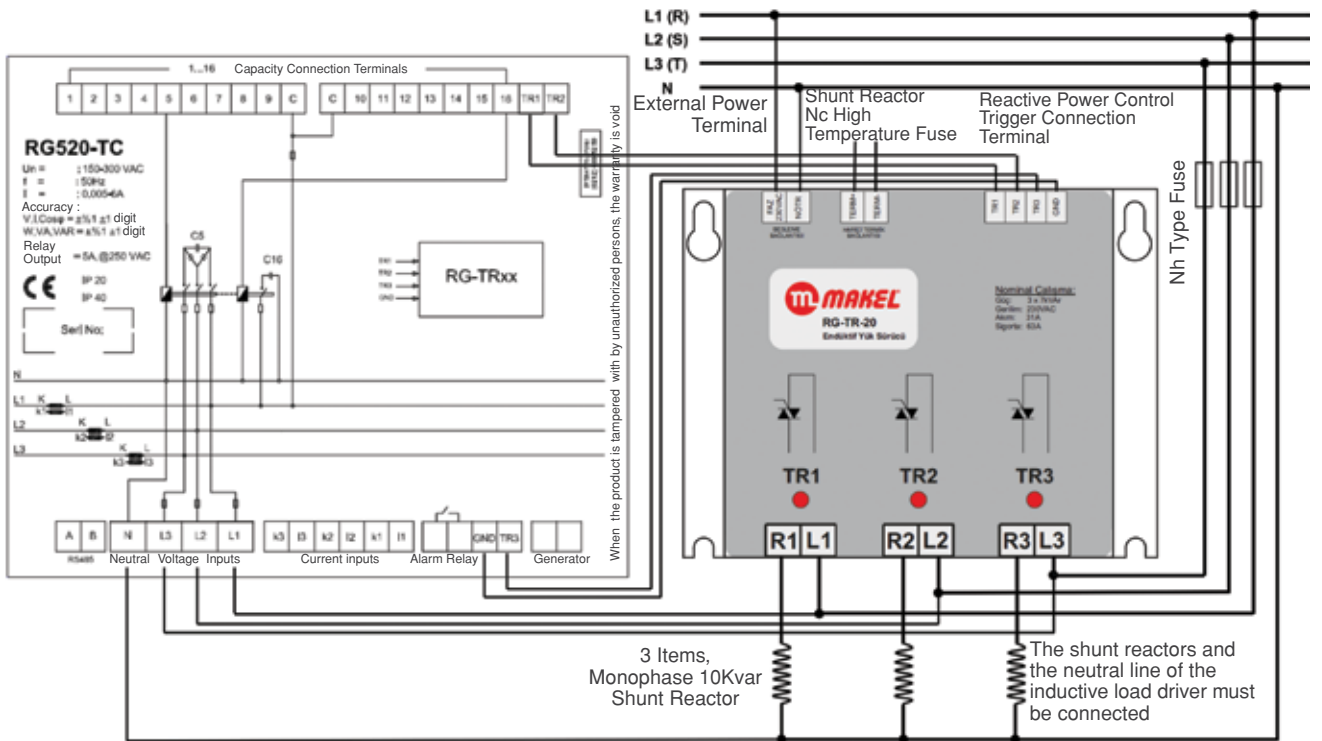
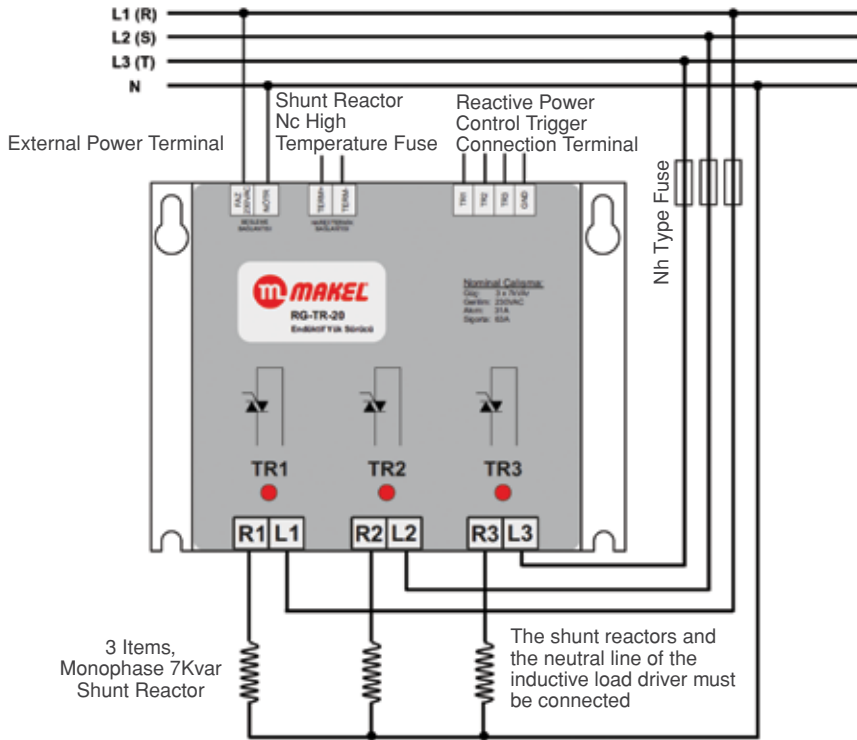

# Wiring Diagrams

RG-TR-30-Diagram

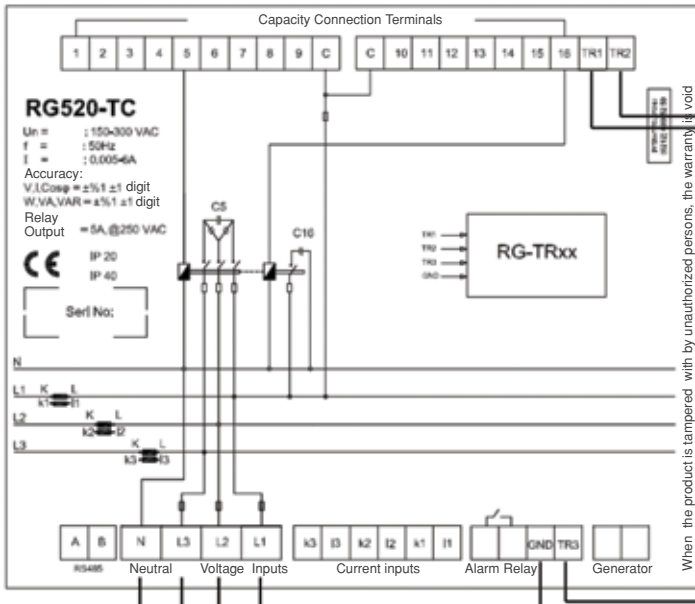
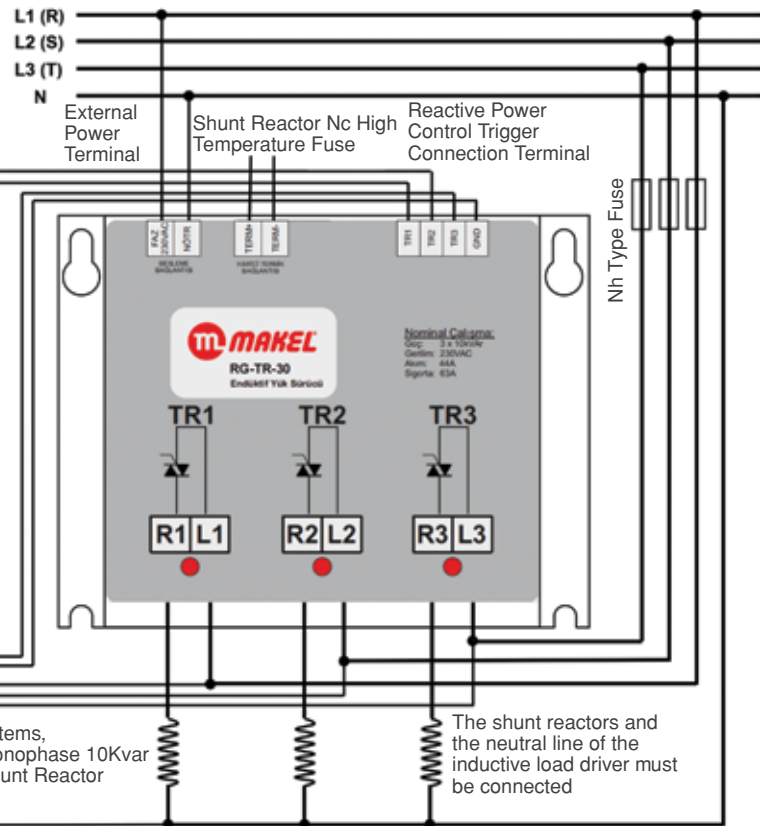
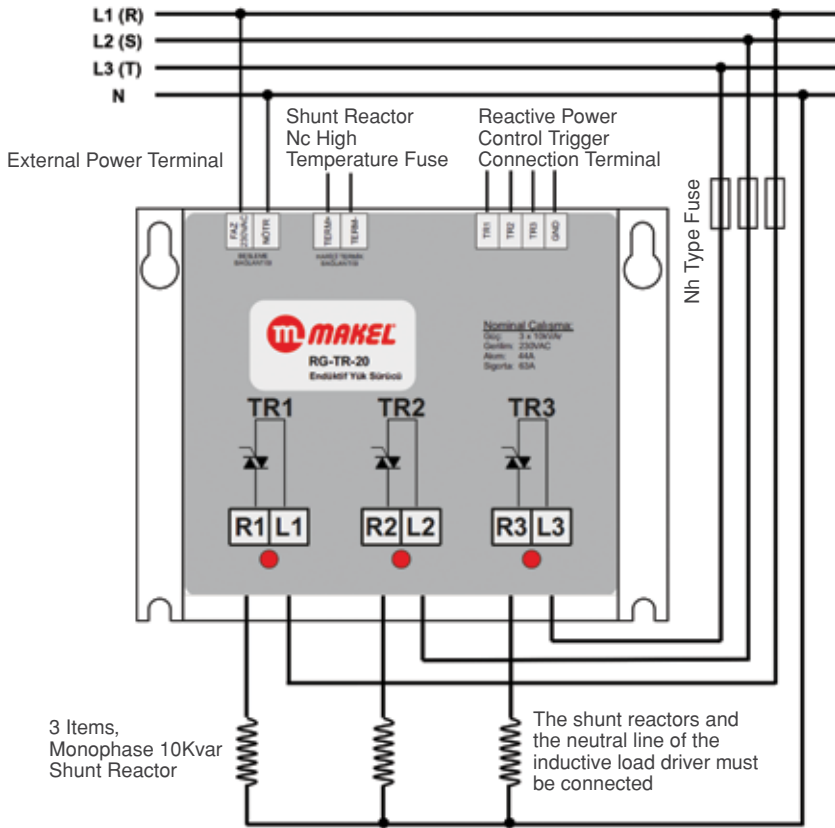

When the product is tampered with by unauthorized persons, the warranty is void